

Product Name: Twin Line Pump Station

Part Number: PSA-TL-02

Applications

Suitable for closed loop domestic hot water solar systems.

Features

- Grundfos 3 speed solar pump
- Flow & return temperature gauges
- Pressure gauge
- Pressure relief valve & connection for expansion tank
- Flow gauge & setter with fill and drain connections
- Air separator with manual vent
- EPP foam insulating casing
- Integrated check valve
- Factory pressure tested
- High quality components

Technical Specifications

System Connections:	3/4" M BSP Thread
Operating Temperature:	Ambient: Max 40°C Liquid: Max 110°C
Thermometer Display Range:	0 - 120°C
Systems Pressure:	Max 6 bar (pressure relief) *
Flow Meter:	2-12 L/min
Suitable Liquids:	Water Max 50% Glycol/Water Mix
Insulation:	EPP, IP44 rating
Circulation Pump:	Grundfos Solar 25-65 (3 speed)
Pump Max Power:	80W (0.35 Amp)
Pump Performance (0.5m ³ /h):	Speed 1: 1.6m head = 45W Speed 2: 4.3m head = 50W Speed 3: 5.5m head = 52W
Supply Voltage:	230VAC, 50Hz
Net Weight:	5.4 kg
Gross Weight:	6.4 kg
Packing Dimensions:	430x350x170mm

* Pressure safety valve complied with Pressure Equipment Directive 97/23/EC

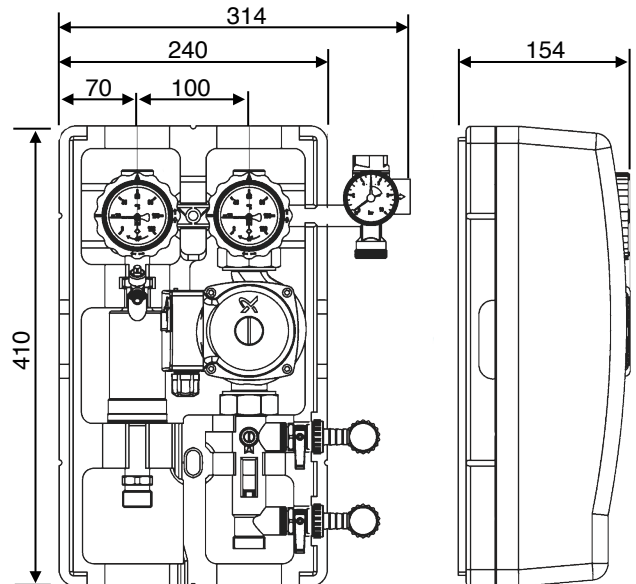

Solar Pump Performance

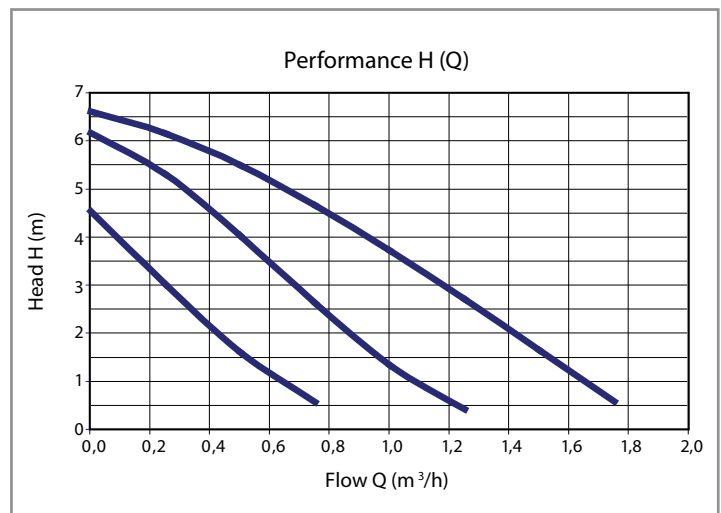

Sustainable HOT WATER Solutions, Delivered by APRICUS

Apricus Solar Co., Ltd
service@apricus.com www.apricus.com